

# PROTOTYPE DEVELOPMENT OF AN ICT SYSTEM TO SUPPORT CONSTRUCTION MANAGEMENT BASED ON VIRTUAL MODELS AND RFID

PUBLISHED: June 2009 at <http://www.itcon.org/2009/19>

EDITORS: Kazi A S, Aouad G, Baldwin A

**Kristian Birch Sørensen, M.Sc. (Civ. Eng), Master of IT, PhD candidate**  
Ramboll Denmark and Aalborg University, Department of Civil Engineering  
[ksb@ramboll.com](mailto:ksb@ramboll.com), <http://www.ramboll.com>

**Per Christiansson, Professor, Dr.**  
Aalborg University, Department of Civil Engineering  
[pc@civil.aau.dk](mailto:pc@civil.aau.dk), <http://it.civil.aau.dk>

**Kjeld Svidt, Associate Professor, PhD**  
Aalborg University, Department of Civil Engineering  
[ks@civil.aau.dk](mailto:ks@civil.aau.dk), <http://it.civil.aau.dk>

**SUMMARY:** *There is a need to develop new information and communication technology (ICT) systems with better support of the contractor's working practice in order to gain more advantages from the virtual models created during the design of buildings. For this reason, a Contextual Design of a prototype (an early example) of an ICT system was carried out to identify and formalise user needs in relation to construction management based on virtual models and radio frequency identification (RFID). The prototype was developed to support working processes in real-time project progress management, quality assurance and inventory management.*

*In this paper a number of user needs for future ICT systems are presented. The needs are captured during the prototype development process and include that future ICT systems must be more user-friendly, enable object-oriented quality assurance procedures, capture data to be used in process optimisation (lean construction), support a wide range of user environments ranging from mobile phones to large displays for presentation and editing data shared in virtual model resources, enable real-time tracking and location of machines and materials, and integrate traditional document/drawing based working practice with the use of virtual models to enable an easier adaptable change process for the construction industry.*

**KEYWORDS:** *Construction management, radio frequency identification (RFID), virtual design and construction, Contextual Design, future user needs, user environments, mobile ICT.*

**REFERENCE:** *Sørensen K, Christiansson P, Svidt K (2009) Prototype development of an ICT system to support construction management based on virtual models and RFID, Journal of Information Technology in Construction (ITcon), Vol. 14, Special Issue Next Generation Construction IT: Technology Foresight, Future Studies, Roadmapping, and Scenario Planning, pg. 263-288, <http://www.itcon.org/2009/19>*

**COPYRIGHT:** © 2009 The authors. This is an open access article distributed under the terms of the Creative Commons Attribution 3.0 unported (<http://creativecommons.org/licenses/by/3.0/>), which permits unrestricted use, distribution, and reproduction in any medium, provided the original work is properly cited.



## 1. INTRODUCTION

Lack of quality and too many defects are well-known challenges in the construction industry. Many previous research projects have identified the causes and cost of these defects in construction. The purpose of the research presented in this paper is to form a background for a future information and communication technology (ICT)

system development to address these challenges. This is done by capture of user needs and prototype (an early example) development in relation to construction management, virtual models, and automatic object identification by means of radio frequency identification (RFID) technology.

## **1.1 Challenges in construction**

In Josephson and Hammarlund (1999) an overview of several studies of defects in building projects from 1969-1992 is given. In this overview the cost of defects occurring during production is stated to be 2-6 % of the cost of production. The cost of defects occurring during the maintenance phase is stated to be 3-5 % of the production cost. No figures are given regarding the briefing and design phase due to a limited number of studies on these phases in the construction process. Josephson and Hammarlund (1999) also present results from an extensive study on causes of defects where seven building projects was monitored during 6 months. No single reason for defects can be given, and Josephson and Hammarlunds analysis shows that on average 32 % of the defect cost derive from the early phases, i.e. in relation to client influence and design. Approximately 45 % of the defect cost derives from the site, i.e. in relation to the site management, and the workers and subcontractors' activities. Approximately 20% of the defect cost derives from materials and machines. The causes of defects are difficult to identify, but it is stated that on average 50% of the defects are caused by lack of motivation. However, only a few of these are intentional. 29% of the defect costs are caused by lack of knowledge, and 12% of the defect costs are caused by lack of information. A small part is due to lack of communication, stress and calculated risks. Josephson and Hammarlund's results show that the causes of the defects can be found in: 1) Key persons in the client organisation were often replaced, 2) client's long decision time, 3) user involvement in the late stages, 4) time pressure, 5) changing project organisations, 6) cost pressure, 7) lack of support to site managers from their main offices, 8) lack of activities aimed at motivating workers on site.

Findings from the Danish research project "Snublesten i byggeriet" (Stumble stones in construction), and a case study on a 3500 m<sup>2</sup> residential building conservatively estimate the direct and indirect costs of defects to be 8% of the production cost (Apelgren et. al, 2005). In this project the most frequent causes are stated to be: 1) Deficiencies in communication and cooperation, 2) mistakes and weaknesses in the design, 3) lacks in production planning and preparation, 4) insufficient project information handover meetings, 5) mistakes by contractors due to lack of competences and few resources allocated to instruction and control.

## **1.2 Information and communication technology to increase productivity in construction**

The Danish Government has in the project "Digital Construction" (DC) promoted enhanced use of modern information and communication technology (ICT) to facilitate increased productivity through better coordination between the different phases of the building project (NAEC, 2005). The project ran from 2003 to 2006, and the focal point of DC was the vision of an object-based working method, where all project data are associated with a virtual 3D model that gradually develops through the life cycle of the construction. The visible results of DC are a statutory about requirements for the use of information and communication technology in construction (NAEC, 2006) supplemented by recommendations for new working methods (bips, 2007).

The main aspect of the working methods described by bips (2007) is practised in Ramboll Denmark today. It concerns use of building information modelling (BIM) in the design phase, collecting discipline models to aggregated models, consistency check, etc. The immediate advantages are great, and the author's experiences using this new working method in practice show that it; 1) introduces fewer errors, 2) gives a better production basis, and 3) improves clarity and enhances communication methods compared to traditional 2D drafting methods. Other researchers have recently reported similar productivity gains using virtual modelling compared to traditional drafting (Sacks and Barak, 2008; Woksepp, 2007).

No single method can solve all the challenges indicated above. However, the use of modern ICT in the design phase has proven to address some of the challenges. Therefore, it is expected that improved use of similar technologies in the construction phase may reduce defects and increase quality in construction by improving knowledge and information handling, project transparency, project and quality management methods as well as knowledge capture in general. It is expected that a better link (both in digital terms and working process related) between the virtual models and the physical components in construction will be an important future development to achieve the benefits from using virtual models in construction. Such a digital link can be created by means of radio frequency identification technology (RFID). See Sørensen et al. (2009) for an introduction to this technology, its application in construction, and an overview of related ontologies.

Virtual modelling and virtual models are not new inventions, hence the terms have been used in many contexts and also under different names since the mid-seventies, where the first prototypes for use in construction were

introduced (Eastman et al. 2008). Today, in construction practice and in research, terms like object-oriented model, information model, 3D model, building information modelling (BIM) model and virtual building model are often used interchangeably. In this paper the term virtual model is used to describe any digital parametric object oriented product and process model of a physical object (e.g. a person, a building part, a room, a house, a city or a planet, etc.). The term “virtual model” is used rather than e.g. BIM model or virtual building model to reflect that the subjects discussed are not only applicable to buildings, but also generally applicable in the construction industry. The virtual model often, but not necessarily, contains a geometrical 3D representation of the modelled objects. BIM is the term used to describe the process of creating and using virtual models of buildings.

The RFID technology is today mature enough for practical implementation in construction (Sørensen et al., 2008, Chin et al., 2005) but a wider introduction to the industry is still to come. Some significant reasons for this are lack of de facto ontologies enabling easy interorganisational information exchange (Sørensen et al., 2009), as well as poor human computer interfaces and software applications enabling the user to achieve the benefits from the technology. Rather than trying to enforce a technology push on the construction industry, the intention of the research underlying this paper is to identify the actual user needs in construction in relation to linking virtual models with physical components in construction. The acquired knowledge is then used to develop prototypes of ICT systems that can fulfil as many of the identified needs as possible. This is the first step in a system development and redesign of working processes towards enhancing construction management by means of virtual models and RFID.

### **1.3 Outline and conclusions of the paper**

Firstly, this paper gives an introduction to the context of the research. Secondly, the methodology Contextual Design used for the research is presented followed by section 4. Contextual inquiry, 5. Consolidation, 6. Work models, and 7. Vision, Work-redesign and Storyboard that describes the findings from the Contextual Design process underlying the prototype developments described in section 8. Mock-ups. Finally, recommended future extensions of the functionality of these prototypes and conclusions are given.

The conclusions are that new ICT systems that support on-site working practice better than prior systems are needed. They must 1) enable the contractor to easily monitor and present project progress, 2) enable object-oriented quality assurance, 3) support a wide range of user environments ranging from mobile phones to large displays for presentation and editing data shared in virtual model resources, 4) enable real-time tracking and location (by GPS) of machines and materials, 5) capture data to be used for work process optimisation, and 6) predict constructability problems before they cause trouble at the construction site. Future ICT systems must also provide a better integration of the traditional paper document/drawing based working practice with modern virtual model based working paradigms. This is needed to enable an easier adaptable change process for the construction industry. Requirements for and prototypes of ICT systems that address these user needs are presented in this paper.

## **2. CONTEXT OF THE RESEARCH**

A number of cases have been studied to identify the user needs in relation to linking virtual models with physical components in construction. The cases represent a broad segment of working processes in the construction industry, from design to construction and operation.

The research is based on studying working processes taking place in relation to the Department of Buildings, at Ramboll in Aalborg, Denmark. Ramboll Denmark is part of the Ramboll Group, which is a leading Nordic provider of knowledge services with more than 8,000 employees and activities all over the world. The company is operating in a broad international context from 130 offices in the northern European region, and from around 25 permanent offices in the rest of the world (Ramboll, 2008). The Ramboll Group provides engineering, consultancy, product development and operation services within the areas of buildings, water and environment, infrastructure, telecommunication, industry, management, energy and IT.

The Department of Buildings in Ramboll, Aalborg, has approximately 60 employees, and delivers engineering services primarily within design of buildings for power stations, hospitals, cultural activities, industry and residential purposes. It is a multidisciplinary department with competences in structural engineering, ventilation and MEP (Mechanical, Electrical and Plumbing) engineering as well as facility management. At least 20% of its revenue derives from international projects. The department has since 2004 worked on implementing BIM and is today leading in this field among engineers in Denmark.

The research reported in this paper has focussed on how contractors and clients can benefit from the virtual models created during the design process (at Ramboll). Focus has also been on identifying how this can be supported by a link between the virtual models, and the physical components and how ICT systems supporting this link should look and function. The other companies involved in this research are customers and working partners of Ramboll.

The cases studied used in this research are construction management at Aalborg Engineering and MT Højgaard, and precast concrete element fabrication at Fårup Beton Industri and Spæncom. In parallel to the research presented in this paper, future user needs in relation to facility management were also studied. For further information about this case study see Sørensen et al. (2008). After an introduction to the methodology used in this research project the three cases underlying the research are presented.

### 3. RESEARCH METHODOLOGY

A Contextual Design of a prototype ICT system has been carried out to identify and formalise user needs in relation to automatic object identification for construction management. Contextual Design is a method developed by Beyer and Holtzblatt (2000) to handle the collection and understanding of data from field studies to design of software based products. In the software design process, the method is here used as an important tool to collect the right input for a system specification. It is therefore a natural predecessor for an object-oriented system implementation with detailed system modelling based on e.g. Rational Unified Process (RUP) and UML modelling (Jacobson et al., 2005). As described in Göransson et al. (2003) Contextual Design and RUP can by advantage be combined in ICT system development.

The Contextual Design method is user centred, and the following techniques are used in the method:

**Contextual Inquiry:** Interviews, workshops and observations of future users in their actual working environment are carried out to get an understanding of the business problems that the system must support. It ensures capture of the real business practice and daily activities and not just self-reported issues and company policies.

**Work-modelling:** Drawn models representing the users' work practice allow the developer and end user to attain a common understanding and share their findings. It includes work flow models, sequential models of tasks, cultural models, and models of the physical environment and the used artefacts.

**Consolidation:** All the individual findings from interviews, brainstorming and work modelling are grouped in hierarchies and consolidated to show common patterns.

**Work-redesign and visioning:** Based on reviews of the models a vision of how the new system will support and streamline the working practice is sketched.

**Storyboarding:** A sketched and written story is created including sketches of future user environment and narrative descriptions of how it all will work in practice. The story will function as the common understanding between end users and developers of how the system will work and which functionality it will have.

**User environment design:** Based on the storyboard a single model of functionality and organisation of a user environment is created.

**Mock-up and test with users:** Paper based mock-ups/prototypes of the user interfaces are designed and evaluated in user tests. The level of detail of these mock-ups is increased through the development process starting with very simple sketches.

The above presented process is iterative and incremental, which means that findings from one step in the process will lead to updates of both the preceding and following steps in the process. The design is initiated from rough sketches, notes and simple models, which are detailed through iterations in the research and development process.

Compared to other methods from social science (see e.g. Alvesson and Sköldbberg (2000) for an overview) used to study human behaviour and actions, Contextual Design offers a complete and easy to use framework. It is well organised and provides modelling tools to formalise the unstructured connections between work processes and the users' needs in relation to ICT system development. The work models developed from contextual inquiries provide a basis for a common understanding between software developers and end users.

In this research project the Contextual Design process (an applied anthropological approach) is supplemented by reviews of available literature within the field, and trail tests of software and hardware to be used in the final

system and for the development. Also demonstration software applications are created and evaluated by future users.

It has been found rewarding to take the design of early paper-based mock-ups of the user interface traditionally created in the Contextual Design method, one step further by giving them some functionality and appearance like the real applications. Demonstration software applications (prototypes) with some functionality are therefore created and used for tests, and collection of user feedback and ideas. It is important to let the users know, that it is only a demonstration application being presented; otherwise they might expect the development process to be in a late state where their input does not matter any more. There is also a risk that they might be disappointed if the final release of the application has a different appearance or functionality due to findings achieved later in the system development process. Besides the end-users, it has also been found rewarding to use the work models, storyboard and prototypes in communication with software developers and other researchers. See Christiansson et al. (2002) for another approach to using the Contextual Design method for ICT system development in construction.

The contextual inquiry has been done as informal interview's and work observations of future users with different roles in relation to construction. The users involved in the inquiry are consulting engineers, construction site managers, and workmen. Observations at construction sites, factories and offices where the system is going to be used was also made. More than 20 future users have been involved in the inquiry process. The level of involvement in the Contextual Design process has varied for the users. Some construction managers have been highly involved in both the formulation of ideas, inquiry in own organisation and evaluation and development of prototypes and scenarios. Other engineers and construction workers have participated in workshops or meetings, and some have been observed during their daily work and asked for their opinion and feedback on the on-going prototype system design.

The identified needs are supplemented by input from discussions with colleagues, software developers and other researchers to form the presented requirements, consolidated work models and prototypes. In Beyer and Holtzblatt (2000) it is stated that interviews of 10-20 users are enough to collect most of the user needs. More interviews will not result in significantly more identified needs. The design process and the outcome of it are documented in the following sections 4-11 of the paper.

## **4. CONTEXTUAL INQUIRY**

As described in section 3, the contextual inquiry was conducted as interviews, workshops and observations of future users in their actual working environments. The contextual inquiry has taken place in the three cases described below.

### **4.1 Case 1 – Construction management at Aalborg Engineering**

Aalborg Engineering is a Danish company specialised in designing and supplying steam boiler systems and heat recovery steam generators (HRSG). The company is based in Aalborg, Denmark, but its approximately 30 employees work worldwide, and most of the turnover comes from international projects. Aalborg Engineering has a standardised product package of boilers to power stations and industries with high energy consuming processes producing waste gas steams. The services often include design, procurement, production, erection and commission of the full boiler system. Each boiler system is uniquely designed and customised to the needs of each individual customer. (Aalborg Engineering, 2008)

The equipment and components for the boiler systems are purchased in various countries by Aalborg Engineering, and the erection work is carried out by subcontractors. The steel structures supporting the steam boilers and the surrounding footbridges, service decks and staircases are often designed by Ramboll, described in section 2 of the paper. Ramboll and Aalborg Engineering have an informal partnership from working together on boiler systems for 10-15 years.

The processes studied at Aalborg Engineering are those concerning management of construction and design of the steel structures in the steam boiler systems. In this case study the contextual inquiry is based on semi-structured interviews and the first author's observations from working in the Department of Buildings at Ramboll Aalborg.

Semi-structured interviews were held with head of department and assembly managers at Aalborg Engineering and with building technicians at Ramboll.

## **4.2 Case 2 – Construction management at MT Hojgaard**

MT Hojgaard is one of the largest general contractors in Denmark with about 5000 employees. The company works in Denmark and internationally with any kind of buildings and infrastructure projects including bridges, residential buildings, industrial and cultural buildings, roads, project development, etc. (MT Hojgaard, 2008)

The building project used in this case study is a traditional two-storey Danish office building of 3700 m<sup>2</sup> including a basement. It is a public-private partnership project, where MT Hojgaard is the general contractor, Ramboll is consultant on all engineering services, and the architectural firm is the company Cubo. The carcass of the building is prefabricated of concrete elements, which is the most common construction method in Denmark. The working processes concerning precast concrete element design, fabrication and erection have formed the basis of the contextual inquiry and design presented in this paper. These processes were selected because they represent a complex multi-disciplinary task. If we can develop a method to support services for this complex multi-disciplinary task, it is expected that it can be applied to many working processes in construction.

The future users involved in the inquiry from MT Hojgaard are construction site managers, IT-managers and workers at the construction site.

## **4.3 Case 3 - Construction management at Faarup Beton Industri and Spaencom**

Precast concrete elements are one of the most common building components for carcasses of buildings in Denmark. They are produced at approximately 30 factories widely spread in Denmark. Two of the companies producing and mounting precast concrete elements in Denmark are Faarup Beton Industri (FBI) and Spaencom. They produce walls, slabs, beams, and columns from unstressed reinforced concrete, and Spaencom also uses prestressed concrete in their slabs and beams. Contextual inquiries of the management and production processes of precast concrete have been made as observations at three of FBI and Spaencom's factories. The observations have been supplemented by informal interviews of production managers and engineers at the factories. Spaencom delivered all precast concrete elements to the building described in Case 2, and for that reason their processes concerning element mounting were studied in combination with Case 2.

## **4.4 Examples of information captured from the contextual inquiries**

Early sketches of existing working processes and rich pictures describing ideas to new systems have been created on basis of the inquiries in the case studies. These sketches were consolidated through iterations in the design process and have formed the basis of the consolidated work models presented in section 6 of the paper. Examples of these early sketches are given in figure 1. Notes supplementing the sketches have also been taken and these are presented in the affinity diagram in section 6 of the paper.



FIG. 1: Examples of photos and sketches collected during the contextual inquiry.

## 5. CONSOLIDATION

In the Contextual Design method, affinity diagrams are used to organise the individual notes captured during interviews, observations and tests into a hierarchy of common issues. The hierarchy is built bottom up by creating a structure from the content of the notes collected during the design process. Inspiration to the structure has also been found in Wamba et al. (2007). The affinity building is the first step in consolidating the captured observations and user inputs to formalised requirements for the future system. A number of future user needs and comments have been collected. They are as earlier mentioned based on study of existing working processes and discussions with future users about working processes involving virtual models and automatic identification using RFID. Focus has been on use of these technologies in the construction management process. For a comprehensive discussion about the general use of virtual models in construction, and other recent case studies, reference is made to Eastman et al. (2008). To keep the broad understanding of the users' needs, no distinction is made in the paper between what in reality is possible or financially desirable to implement. From the affinity building it has been found useful to categorise the findings according to their relevance to overall strategy, organisation and working processes, technology and infrastructure, human resources, physical components, virtual models in construction management, quality assurance, and social and political aspects. The individual findings are grouped and presented in the diagram below. A short summary of the most important of these findings are given after the diagram.

*Table 1: Affinity diagram with the captured observations categorised according to their relevance to overall strategy, organisation and working processes, technology and infrastructure, human resources, physical components, virtual models in construction management, quality assurance, and social and political aspects. For each observation it is noted whether the observation is a challenge (C) to be addressed, or a potential (P) to be utilised. (Continued on next pages)*

<b>C/P</b>	<b>Overall strategy</b>
C	Alliances in business networks are needed. No single firm can drive the widespread introduction of RFID in construction themselves.
C	Individual companies in the construction industry must be less reluctant to adapt to requirements from other companies.
C	Functional split in working processes introduce waste of time in the project schedules and encourage each individual trade contractor to sub-optimize their own profit.
C	Clients often exert pressure on the project erection start-up without knowing the risk and potential extra cost they introduce to the project.
P	Procurement and prefabrication in Eastern Europe and China set new demands to logistics, planning and quality assurance in the construction process making RFID an interesting technology to link business processes in intra-organisational settings.
P	Strategic partnerships are needed at overall business level rather than on project level as current practice today.
<b>Organisation and working processes</b>	
C	When sharing and using 4D planning information in intra-organisational settings, new legal agreements must be made.
C	Use of RFID requires integration of interorganizational processes.
C	More focus is needed on experience gathering and knowledge sharing.
C	Start-up meetings must be held with each individual trade contractor introducing him to the new technology and working methods, and letting him know how he can benefit from it.
C	Comprehensive effort is required in the start-up phase of the implementation. Training, interorganizational shared server setup and agreement of information sharing is time-consuming.
C	Planning of work (e.g. mounting of precast concrete elements) is done prior to the arrival of the components on the construction site, while the value of instructions to the working procedure at the time of component registration is limited.
P	Component registration, virtual model update and quality assurance processes can be automated.
P	Better overview of status and production flow by use of new technology gives new possibilities for process optimization. Real-time update of the project status is now possible.
P	New possibilities for visualisation of project obstacles.
P	Improved visibility of project plans by means of 4D views improves the possibilities for involving craftsmen in the planning of their own work.
P	RFID would be useful for component acceptance checking, that is hardly done today.
P	Basic geometry information is detailed in several models. Walls are e.g. modelled by the architect, the structural engineering, and the manufacturer of precast concrete introducing many prospective errors and delays in information handling. A simpler division of modelling tasks, with fewer people responsible for modelling each component, can reduce the risk of errors.
P	New incentives are needed to gain success on implementation of ICT in construction. The ability to create continuous improvements should be rewarded.
P	Facts from measurements are more reliable than personal opinions in process optimisation. For process optimisation using Lean Construction or Six Sigma (Pyzdek, 2003), the detailed registration gives new possibilities to compare planned and accomplished construction.
P	New possibilities for linking and synchronisation of information between physical components and their associated documents, such as specifications, detailed fabrication drawings (both 2D and 3D views), and maintenance instructions.
P	Transparency of production status and defects for all parties in the project organisation.
P	Visibility of condition, place and status of each component for all parties in the project organisation.
P	Information can be shared among all supply chain players.
P	Traceability after mounting.



Table 1: (Continued)

<b>Technology and infrastructure</b>	
C	The data capturing software and its link to the virtual models are not off-the-shelf items, and therefore requires test and further development.
C	Major investments in new technology are required to gain the benefits.
C	Lack of software interoperability and need of ontology development, see also Sørensen et al. (2009).
C	Integration of CAD, procurement and management tools are required, but today there exist only a few tools that meet these requirements.
C	The network infrastructure must support both mobile and fixed RFID readers, antennas, sensors and equipment.
C	New hardware is required for visualisation at the construction sites such as big screens, projectors and screen technology working outdoor in a harsh environment.
C	Methods and tools for sharing 4D model information are needed.
P	A combination of GPS and RFID will be useful for inventory management, especially at large construction sites.
P	The mobile phone is a known technology among everyone in construction, and the resistance to use it is limited.
P	Reuse of tags from construction in facilities management would be beneficial.
<b>Human resources</b>	
C	New competences are required to make use of the technology on construction sites. Simple tasks for experienced ICT-users such as opening digital drawings from an ftp-server or attaching files to e-mails are often difficult or impossible to accomplish for construction site managers.
C	The middle management (project and department managers) must have the competences to drive the change process, otherwise new resources are required. It could be a project information officer (PIO) who would be responsible for introducing the technology at the construction site. (See Froese and Han (2008) for further discussion about this topic.)
C	To ensure a successful technology implementation a number of tasks to be conducted by the project information officer has been identified: 1) Ensure data quality and accessibility of discipline and aggregated models, 2) support in setting up procedures for information exchange, 3) administrate information and knowledge sharing portals, 4) conduct systematically cross-disciplinary consistency control of virtual models, 5) be the human link between the IT operation organisation and the project organisation, 6) support and influence the owner's and the contractors' use of ICT, virtual models, and ontologies 7) keep the virtual models updated during the whole construction period, 8) support construction site use of the virtual models by e.g. ad hoc creation of bill of quantities and visualisations, 9) train the construction team in the use of ICT.
C	New competences are needed on the construction site combining skills of a traditional civil engineer with the competences of an IT engineer. (See Steinmann (2005) for further discussions on this topic)
C	There is a risk of disregarding the unskilled labourer in the technology implementation process.
C	It is hard to find resources for innovation and implementation of new technology within the existing business processes. Often, when a milestone in the project must be reached the innovation and implementation of new working methods are put on hold.
C	Considerable human resources are required to keep the virtual models up to date through the construction process.
C	Managers, consultants and workers have different views on the need for new technology in construction.
P	Great possibilities to design and implement adapted human computer interfaces for different usage and contexts.
<b>Physical components</b>	
C	There is need to standardise the placement of the tags, especially in components where the RFID tags are hidden in the component. Inspiration could be found in currently used standards for labelling.
P	The tag can also be used for orientation of the components.
<b>Virtual models in construction management</b>	
C	Filtering, proper visualisation, and structuring of data are important to achieve the needed performance of the virtual models to gain benefits of RFID.
C	Lack of interoperability puts extra demands on choosing the right software because it is not possible to change the software and keep transferring all object properties from one tool to another.
C	Usability improvements are required in model viewers and in methods and tools for sharing models. Especially the aggregated multidisciplinary models and 4D models are hard to navigate for non ICT experts.

Table 1: (Continued)

C	Standardisation of 4D views (colours of object representation) are required to make the views easier to read.
C	New method (digital or paper-based) for exchange of 4D model information is required.
C	It is difficult to print useable 4D views, objects are often hidden behind each other.
C	Automatic link between objects and schedule is required. Otherwise it is too time consuming to keep the virtual model updated.
C	The demands on the quality and time of delivery of virtual models from the design team, are increased, if the models are used as construction management basis.
C	Colour blind people can have difficulties using colour-coded 4D model views.
C	Data captured during the construction process must be reusable in operation and maintenance.
C	Virtual models must be extended with functional building system ontologies to better support the link between the building functional services and the building's component system.
C	Handling of changes or deletion of objects in the virtual model after the RFID tag has been added to the physical component can cause problems.
P	Standardised Web service interfaces to the virtual model resources are expected to reduce the implementation time for data capturing and data presentation tools.
<b>Quality assurance</b>	
C	2D, 3D and 4D overviews are still needed, even though quality assurance is done by use of a hand-held device such as a mobile phone.
P	Less paper is needed in the quality assurance (QA) process because of automatic object identification.
P	By adding the QA data to objects in the virtual model, the data can be reused. Today it is hard to find any useful information from the QA documentation.
P	Process optimization can be done on the basis of the structured quality assurance documentation.
P	The production of QA documentation material for project handover can be automated.
<b>Social and political aspects</b>	
C	Risk of undesirable surveillance
C	Radiation from the RFID reader/antennas might scare people
P	Improved documentation of the production process and delivered quality might be a client requirement as is the case with the use of virtual models and ICT today in Denmark (NAEC, 2006), Norway, Finland, Netherlands in with governmental projects.
P	New requirements for CE marking of construction components (European directive) demand unique traceability.

## 5.1 Summary of the affinity diagram

For a successful future system development and implementation, it can from the affinity building be summarised that focus is necessary on: 1) development of new partnerships and business models, 2) integration of interorganizational working processes, 3) combination of automatic identification technology and lean construction principles can enable new possibilities for process optimisation, 4) lack of interoperability and de facto standards are a considerable challenges, 5) mobile phones can be an important key to introduce a wider use of RFID in construction, 6) integration of tools for CAD, procurement and construction management, 7) new competences at the construction site to gain the benefits from ICT implementation, 8) innovation and implementation of new technology in construction require major investments, 9) standardised data interfaces to the virtual model resources, e.g. implemented as Web services, 10) use of automatic identification introduces a new object oriented paradigm for quality assurance in construction, 11) there is increased political focus on documentation and knowledge management.

## 6. CONTEXTUAL WORK MODELS

### 6.1 Workflow

Workflow models are used to define and illustrate how work is divided between people, how they coordinate work, and which artefacts (formalised messages and tools) and placeholders (information containers, meeting places, etc.) they use to assist the communication. Usually one work flow model is created per person/role interviewed. However, in this paper it has been chosen only to present one of the workflow models. The workflow model is a consolidated model of how the foreman from a precast concrete element team acts in an on-site problem solving process, see figure 2. This workflow model illustrates currently daily practice, and therefore

it shows the working processes that should be supported and hopefully improved by automatic object identification and use of virtual models. Each person or user role is shown in the bubbles annotated with their responsibilities listed below their job title. The rectangles in the workflow model show the artefacts and placeholders used for information transfer between the people. The photo placed next to the workflow model in figure 2, shows a snapshot of the modelled work process.

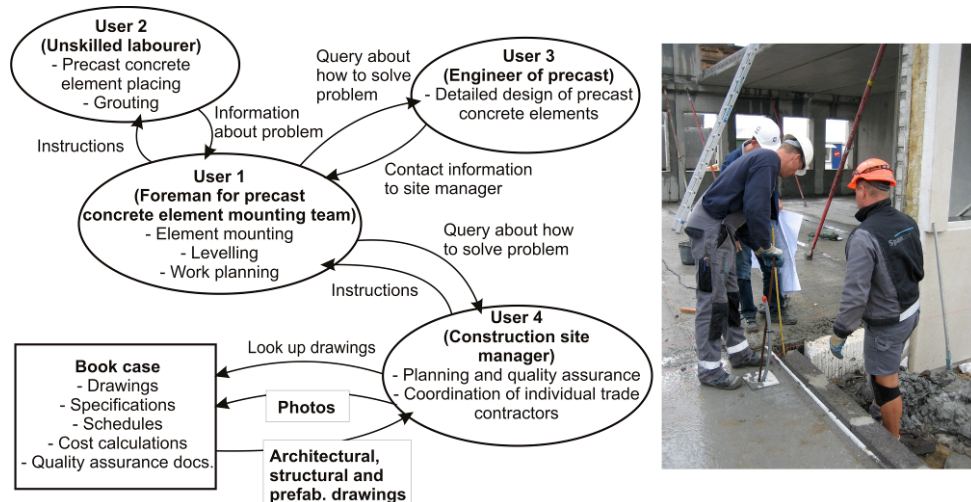
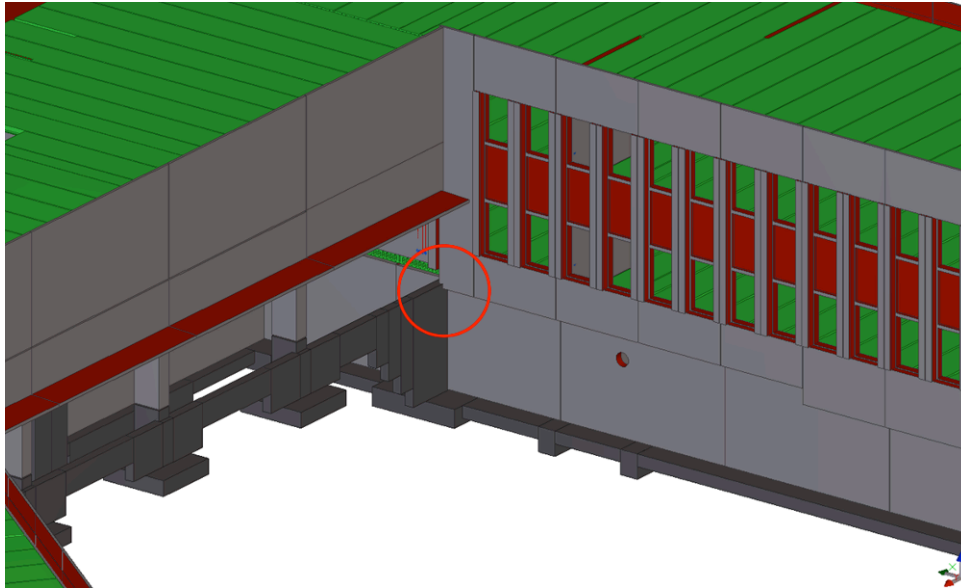

FIG. 2: Workflow model of a problem solving process. The photo next to the model illustrates the process at the construction site. Bubbles illustrate roles, and rectangles illustrate artefacts (formalised messages and tools) supporting the information transfer.

The working process illustrated in figure 2 is one out of many in construction. The more formalised of them are well described today, but in an ICT system development process it is also important to be aware of the unformalised processes like the one illustrated in the figure. In Karhu et al. (1997) a comprehensive set of IDEF<sub>0</sub> models of activities, their interconnections and the information flow between them are modelled. Reference is made to this report for a general overview of the overall processes in construction from the early design stages to completion for handover and use. From an ICT system development perspective the Contextual Design workflow are superior to the IDEF<sub>0</sub> models by being user need oriented rather than task oriented.

From studying the working processes concerning the precast concrete element design and fabrication (Case 2 and 3), it has been identified that up to now, too little effort is invested in virtual model coordination and model consistency check in the design. It has been identified during the observations that when no extra attention is paid to the subject, the first person to bring all the project material together is often the engineer or draftsmen at the precast concrete element manufacturer. Architectural drawings are used to find the right overall dimensions such as height, width and door holes of the element to be produced, and the structural drawings to find details about connections, thicknesses and reinforcement. Finally, it is checked, by use of the MEP drawings, if all mechanical and electrical parts are embedded correctly in the precast elements.

The lack of quality check of the design models results in problems at the construction site as illustrated on the work flow model in figure 2. As shown in figure 3, the problem could easily have been found already during the building design by executing an automatic model check.



*FIG. 3: Virtual model of the problem to be solved at the construction site. Overlapping building components are highlighted by the circle.*

An important topic to investigate further is how the virtual model can support the problem solving process illustrated in figure 2. If the foreman or the site manager in this case should have any advantage of the virtual model he should be supported in the process of finding a solution to the problem. As illustrated with the workflow model of this process he needs information shown on drawings from various disciplines (in this case structural engineer, prefabrication engineer and landscape architect) and contact information to offices outside the construction site. In this case the snapshot from the virtual model presented in figure 3 was not of any use because it showed only the structural model. The precast concrete element causing the troubles was modified to fit the foundation, and information about the final terrain level and reinforcement of the element was needed to make the decision of modifying the precast concrete element. This information was not included in the structural model. For the virtual models to be useful for the contractor at the construction site, they must be easily accessible as aggregated models integrating all disciplines involved in the project. Increased focus on the creation and delivery of aggregated and consistent models are therefore expected to increase the quality of the production basis significantly, and thus making it easier for the contractors to construct the buildings. Whether the consulting engineer, the architect or the contractor should be responsible for creating the aggregated model must depend on their competences, interest and contractual agreements.

## **6.2 Working culture**

Cultural models are used to illustrate, concretise and capture the invisible and pervasive cultural context that influences the system or product to be developed. The authors' interception of the interviewees' behaviour, their informal answers and unwritten values is presented in figure 4. Cultural models are relevant in any system development because cultural aspects can have significant influence on people's choices and thereby the success ratio of the new system. The introduction of automatic identification in construction management may introduce many potential conflicts, as illustrated in figure 4 with the zigzags. In the implementation it will lead to conflicts about who should pay for adding RFID tags to components and further what can the detailed registration of people's behaviour be used for? Also public attitude about the RFID technology, which can be hard to tackle, can have major influence on the technology's success in construction.

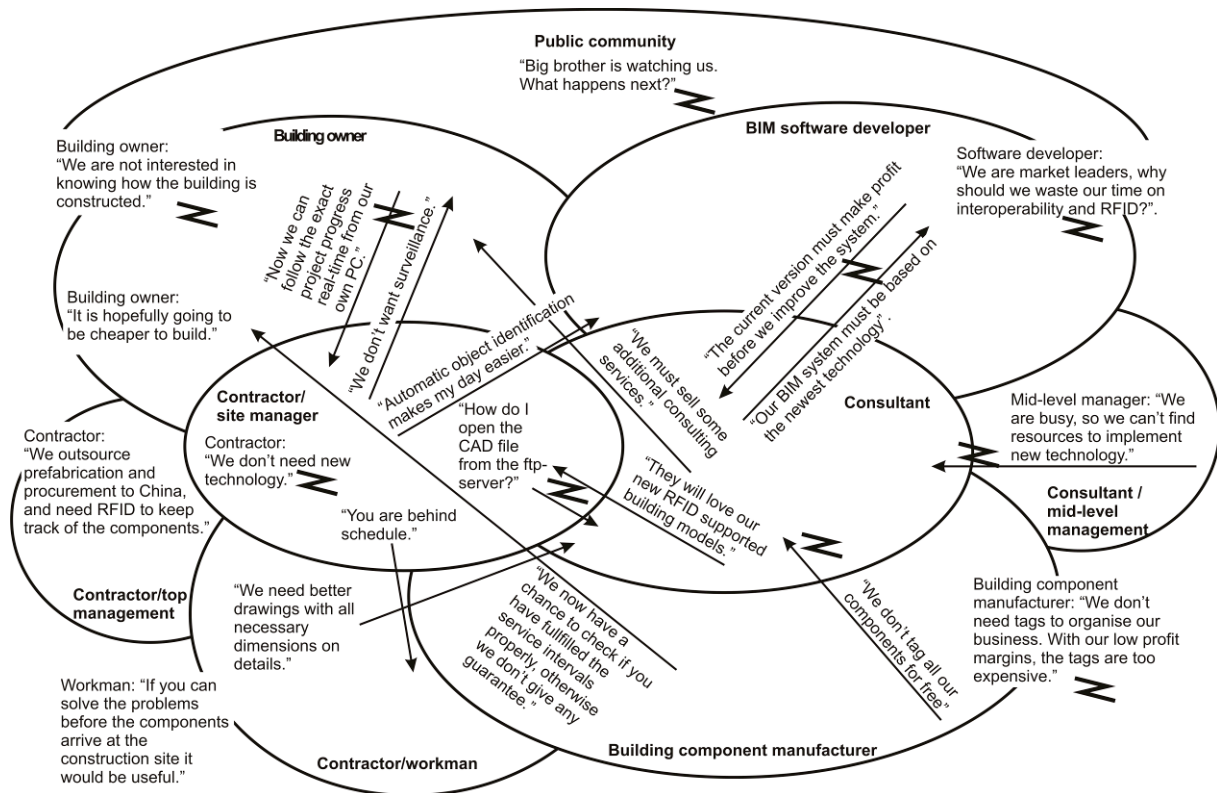

FIG. 4: Cultural model of the context influencing an ICT system to support construction management based on virtual models and RFID. The bubbles illustrate users with overlapping interests, and the arrows illustrate cultural influence. Zigzags indicate conflicts.

### 6.3 Physical environment

Physical models are used to illustrate the physical environment in which the future system is going to be used. It thereby illustrates the physical bindings on the system. In this case, the system under development is not only going to work in a single physical environment, therefore the physical model shown in figure 5 illustrates a generic model of a construction site. The most important constraints illustrated in figure 5 are that a construction site consists of a number of highly distributed physical and virtual spaces. The links between the spaces consist of access roads and supply lines for network, electricity, water and sewer system. These spaces are often moved ad hoc during the construction phase, and the ICT system must therefore be very flexible to support these changes.

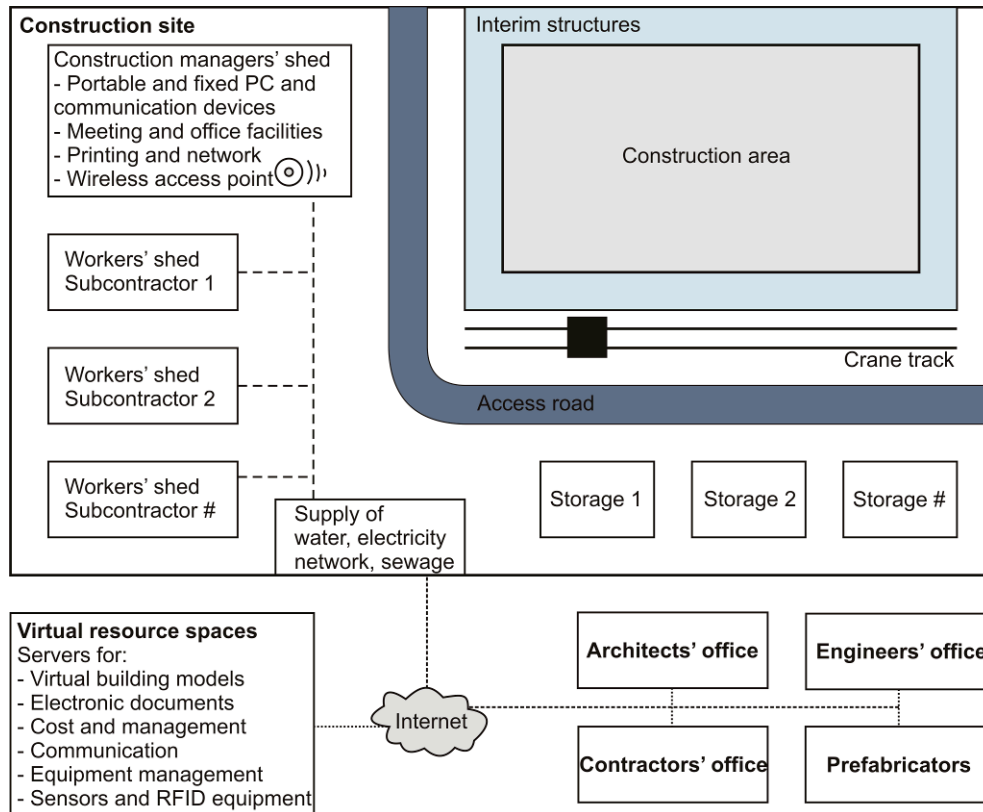

FIG. 5: Generic model of the physical environment at the construction site and the nearest surroundings.

## 7. VISION, WORK-REDESIGN AND STORYBOARD

The findings presented in sections 4-6 of the paper are in this section used for creating a vision of new working processes and a new ICT system. This vision is a concretising of the initially presented idea of a better link between the virtual models and physical objects in construction.

The Contextual Design based research has resulted in a vision of developing a simple and implementable system with supporting work processes for real-time project progress management, quality assurance and inventory management. The system must be flexible and give the user access to virtual model information anywhere, at anytime, and about any component modelled in the system.

Typical use cases of the system will be:

- Construction planning
- Construction site inventory management
- Quality management such as
  - Continuous follow-up
  - Registration of component flow
  - Documentation of quality of work results and project progress
  - Check of compliance with schedule
- Construction process optimisation by delivering measurable input to lean construction and lean Six Sigma process optimisation (Pyzdek, 2003)
- Retrieving work instructions from a virtual model (See also Mourgues (2008))
- Real time visualisation of current project stage
- Visualisation of differences in actual and planned installation order and schedule
- On-site and office information retrieval and notification

A narrative description of how this system will be used is given below. This storyboard has proved to be very useful for presenting and discussing the future system with software developers and future users, and its content has developed through many iterations.

## 7.1 Storyboard

A future possible user scenario is presented below to outline how the system is intended to be used. The scenario is presented by storytelling with the following fictitious protagonists; John the virtual model coordinator, Jane the construction manager, Michael a manufacturer of precast concrete and Paul the foreman, and illustrated in figures 6-10.

### Model generation and precast element management

John is model coordinator of the design and construction of a new office building. His task is to secure a smooth flow of information between all parties in the project. During the design of the building John is responsible for the 3D and 4D modelling and works in close collaboration with the general contractor's construction manager, Jane, and project manager, Michael, from the manufacturer of precast concrete. John is also responsible for adding the ID's from the RFID tags to the objects in the virtual model stored on the model server.

When the concrete elements are ready for shipping, Michael is responsible for updating the 4D production status information on the model server. He does that by reading the RFID tag embedded in each concrete element by his mobile phone, and subsequently he presses the button "In transit". Together with the production status information the mobile application automatically updates the model server with data about time, date, user and current location of the GPS. His mobile phone has Internet access, and connects to the service provided by the model server.

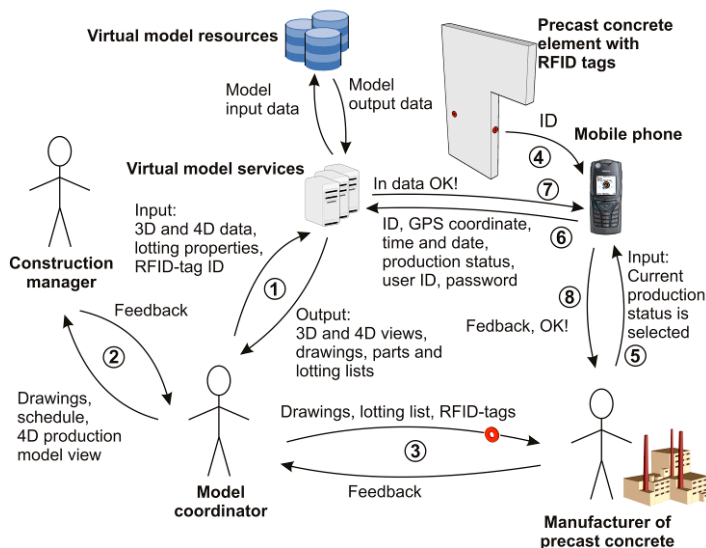

FIG. 6: Rich picture illustrating future use of a digital link between virtual models and physical components in construction for model generation and precast element management. The numbered events refer to an execution sequence of the actions.

### Construction site precast concrete element acceptance and inventory management

When the precast elements arrive at the construction site, Jane uses the RFID enabled mobile phone to identify the elements. Prior to arrival, she has already received information about the elements installation time, date, storey and grid line from the virtual model service. While doing the acceptance check, Jane writes comments on the phone, if any and updates the model server with new element data about production status, location, time, date, and user. The acceptance checking also includes finish, transportation damages and measurements of window and door holes.

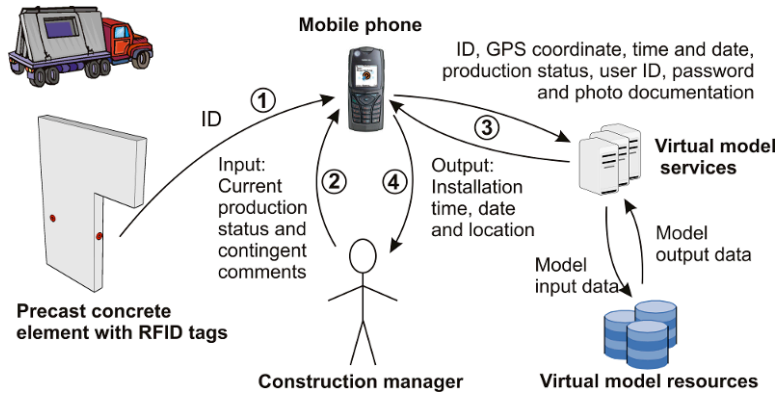

FIG. 7: Rich picture illustrating future use of a digital link between virtual models and physical components in construction for precast concrete element acceptance and inventory management. The numbered events refer to an execution sequence of the actions.

### On site element location

A continued update of the virtual model enables any user of the system to retrieve information about current production status, location, comments and direction of any of the precast concrete elements. Foreman Paul uses his mobile phone to retrieve information about where he can find the next element to be installed, and he reads the comment input during element acceptance at the construction site. In case the element is not in place at the construction site, he is notified where in the supply chain it is currently located.

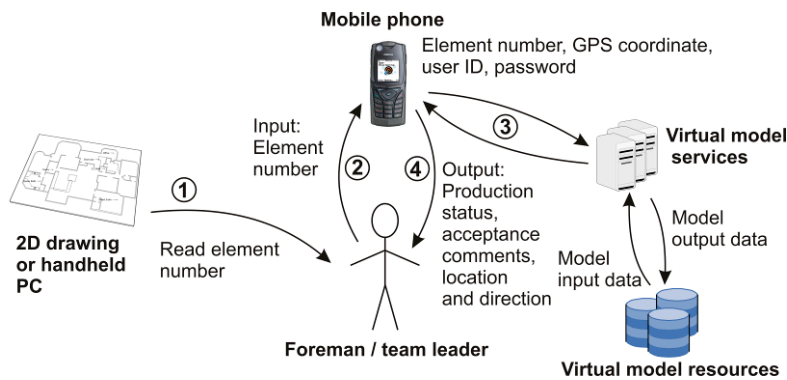

FIG. 8: Rich picture illustrating future use of a digital link between virtual models and physical components in construction for on-site location of building elements. The numbered events refer to an execution sequence of the actions.

### Task accomplished update

When a precast concrete element is installed, Paul updates the virtual model with his mobile phone by reading the RFID-tag and selecting the "Task finished" button. He supplements the input with a photo for the quality assurance documentation. He now receives information about the next task and the location of the elements to be installed.



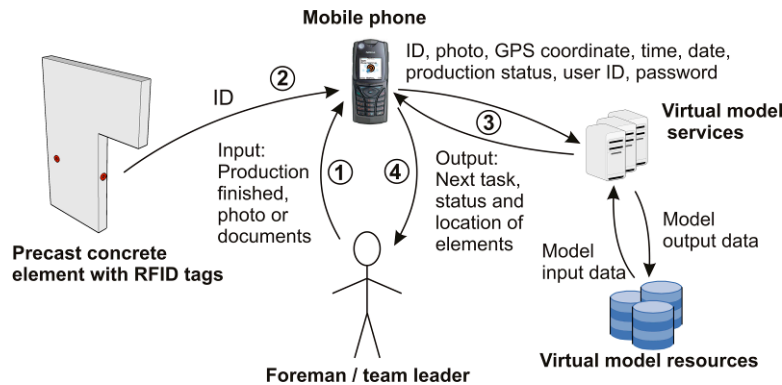

FIG. 9: Rich picture illustrating future use of a digital link between virtual models and physical components in construction for on-going process update of the virtual model. The numbered events refer to an execution sequence of the actions.

### Ongoing information retrieval

During the construction process contractors, engineers, architects and the client can follow the progress of the project in their own offices by means of a virtual 4D model viewer. Furthermore for elements where they have subscribed to notification, they receive an e-mail, SMS or RSS feed (Really Simple Syndication (RSS 2.0), RDF Site Summary (RSS 1.0 and RSS 0.90), or Rich Site Summary (RSS 0.91)) whenever production status of the elements is changing. The structural engineer uses this option to get information about when he has to go to the construction site to do follow-up quality checks, and the construction manager is quickly informed when new elements arrive at the construction site.

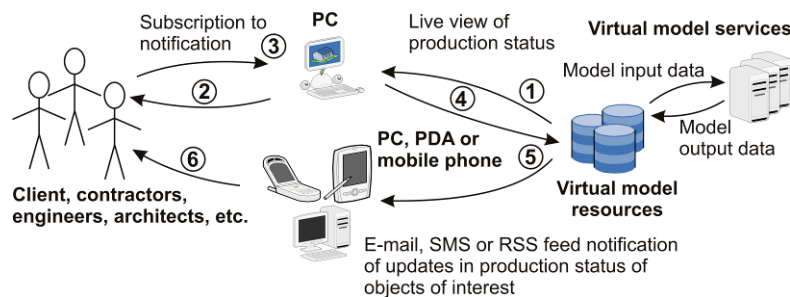

FIG. 10: Rich picture illustrating future use of a digital link between virtual models and physical components in construction for on-going information retrieval. The numbered events refer to an execution sequence of the actions.

## 8. USER ENVIRONMENT MODEL

The findings from the contextual inquiries, work modelling, consolidation, visioning, work-redesign and storyboards described in this paper are used to develop the user environment model presented below. An important prerequisite to enable the real-time project progress management, quality assurance and inventory management is to be able to view, edit, link, and organise the data stored in the virtual model resources. A high-level user environment model for a future ICT system supporting the users in this collaborative information management process is shown in figure 12. The ICT system will enable the users to overview and easy access the electronic information produced and shared during construction projects. This ICT system will therefore be the backbone of managing the project progress, the quality assurance process and the inventory. There exist many useful ICT tools for use in design and construction of buildings, but there still is a need of providing the industry with better ICT systems supporting the general handling of information and resources.

The idea of an integrated interface for information access in construction is not new. In 1984, Christiansson (1984) wrote: "Tomorrow's systems will contain project information which should be highly accessible to many persons during all the design phases of the project." and "To meet this development it is very important to tackle the problem of structuring knowledge and making classifications which are universal enough to be used in integrated systems." Today, some of the challenges of structuring knowledge within construction have been

addressed with the development of the ontology for product and process models, Industry Foundation Classes (IFC), see Liebich et al., (2008). However, there are still challenges in the development and introduction of meta-ontologies and business process ontologies based on functional building systems (Sørensen et al. 2009), (Christiansson, 2007).

The user environment model in figure 12 organises the user needs into focus areas. In figure 11 an explanation of how to read the user environment model is given. For each focus area, (or page/window) in the new system a short description of its purpose is given. The description is supplemented by a short list of related functions, list of links to other focus areas, objects presented to the user, and special risk or constraints relevant to the subject. The main purpose of the user environment model is to form the basis of a future detailed system specification and use case descriptions in the UML (Unified Modelling Language) modelling of the system to be developed. The user environment model can also act as a checklist, allowing system designers to review the function in relevant context and to verify that all the functions are needed and that all needed functionality is available as well as point to artefacts needed to use the system.

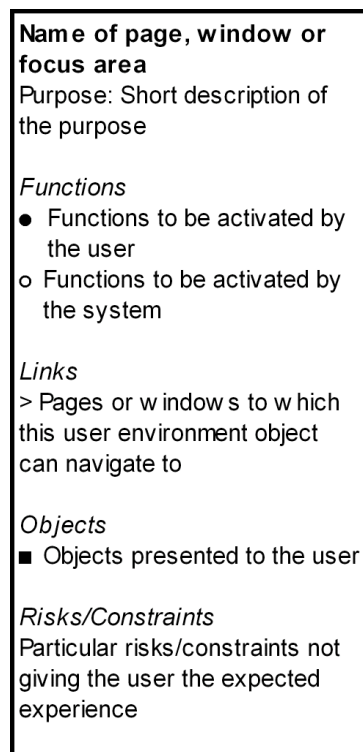

FIG. 11: Explanation to the elements in the user environment model in figure 12.

Documents and drawings in paper or digital form are expected to be important to the construction industry for many years. Therefore as illustrated in figure 12 the new system must provide the user with a combined overview of information stored in electronic document management (EDM) systems as well as in virtual model resources. While the use of virtual models becomes more and more daily practice, it is expected that there will be a transition of information stored in documents to information residing in the virtual model resources.

The system must also enable the user to view the content of the document and virtual model resources. This is illustrated with the “Work area” in figure 12. “Work Area” is linked to the “Model Overview” as well as to “Quality assurance” and “Properties, location and status” providing the user with detailed information about the objects accessed in the “Work area”. To enable a rational handling of information added to virtual models, it is important to give the user good functionalities and artefacts for grouping and linking of the virtual and physical objects. This is included in the model with the “Arrange” focus area. Much of the management of projects in construction concerns handling personal interaction. To support this in a digital manner, communication management is also an important focus area of the ICT system. The system must be individually configured to each user, as well as to the users’ projects and technical services, which is illustrated with the “Services” and “Setup” focus areas. Finally the system must provide the users with sufficient feedback on interaction with the system.

How these overall requirements can be implemented in real ICT systems are illustrated in section 9 of the paper.

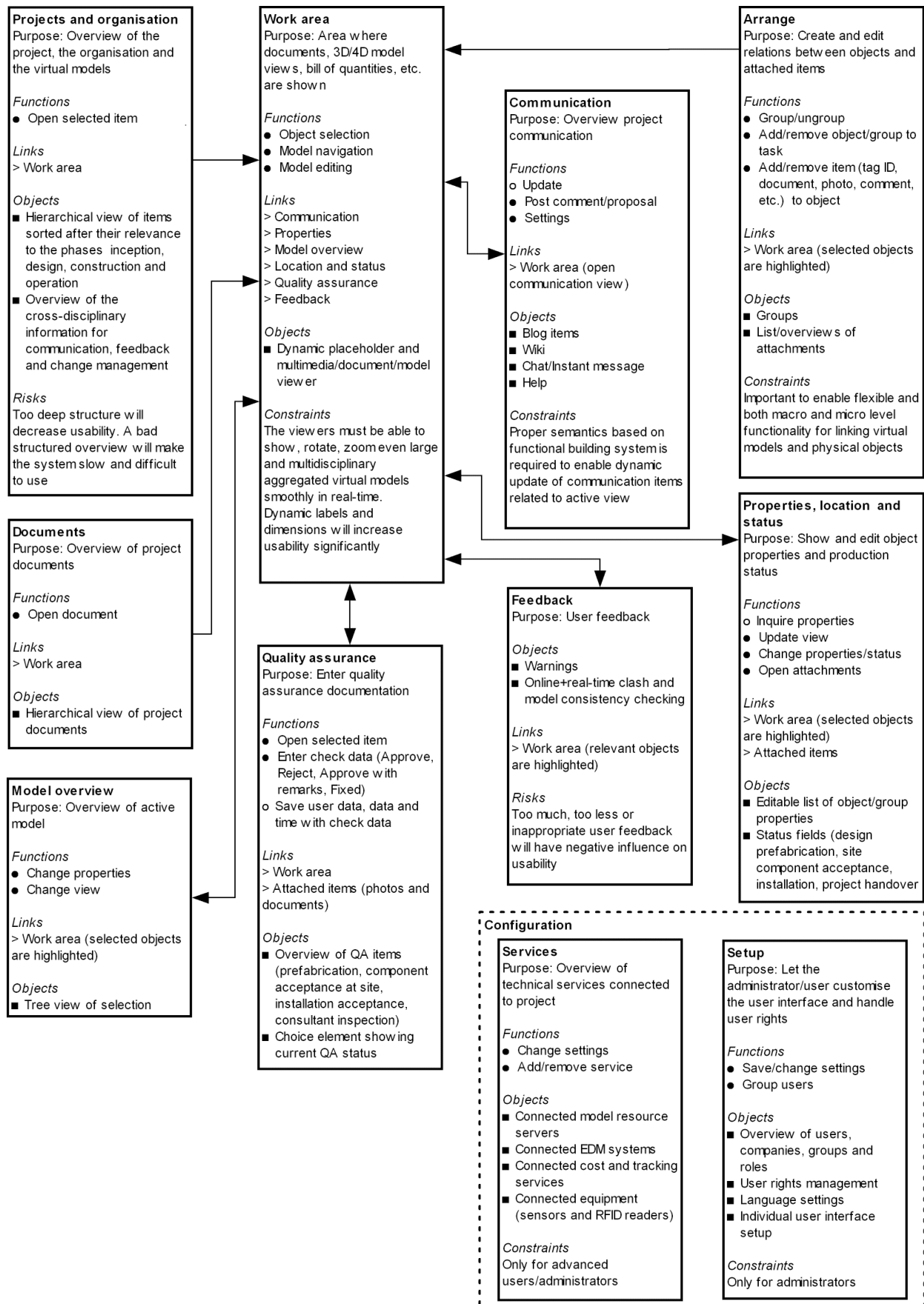

FIG. 12: High level user environment model for a future ICT system supporting project progress management, quality assurance and inventory management in construction.

## 9. MOCK-UPS

A very important aspect in the development of future ICT systems for construction is usability (easy to learn and remember). Today, interfaces for information handling systems used in construction, such as electronic document management systems and model server managers, often suffer from badly designed user interfaces. High usability is a less important aspect in e.g. CAD or numerical simulation systems because they are mostly used by experts. However, in broadly used ICT systems usability is a very important subject to address, especially in the construction industry where the barriers concerning implementation of new ICT systems are often more human grounded than technical grounded. The user interfaces presented below are based on the human-needs-centred system development, presented in this paper, and are therefore expected to provide future system developers with a background for implementing a satisfactory user interface.

Going from paper-based or diagram-based prototypes (the user environment model in section 8 of the paper) to real applications often introduces constraints to the design. Constraints in screen sizes, graphical component dynamics and preferred use of standard user interface patterns to encourage high usability (Nielsen and Loranger, 2006) introduce compromises to be taken into the design. To exemplify how these limitations can be addressed, two prototype systems are presented in sections 9.1 and 9.2. These prototypes can act as a basis for future developments of interfaces to e.g. model server managers and mobile data capturing equipment.

Different use cases require different user interfaces. Firstly, a general ICT system for collaboration and information handling is presented in section 9.1. It is expected to be used on regular PC's and laptops. Secondly, a tool for on-site project progress management and quality assurance is presented in section 9.2. The use of virtual model resources stored in e.g. IFC model servers or in a virtual model authoring tool supporting construction management, such as Tekla Structures or the VICO software suite is common to both systems. The information resources are accessed through the Internet, and RFID tags are used in the systems to create a digital link between the virtual models and the physical components.

### 9.1 User interface for a system for Virtual Collaboration in Construction (V2C)

Besides the user needs and requirements found during the Contextual Design process, the mock-up design has also been inspired by the popular integrated development environments (IDE) used in software engineering, such as Netbeans (<http://www.netbeans.org>), Eclipse (<http://www.eclipse.org>) and Visual Studio (<http://msdn2.microsoft.com/vstudio>). The IDE Netbeans is illustrated in figure 13 (left), together with the developed prototype system named Virtual Collaboration in Construction (V2C). The user interface is developed using standard Java Swing Components (Java, 2008). This prototype illustrates how the requirements found through the Contextual Design process, and consolidated in the affinity diagram and user environment model, can be implemented in practice.

It is expected that a system implementation of the presented prototypes with focus on user needs and e.g. based on an open business model (Chesbrough, 2006) could be an important step towards a more comprehensive use of virtual models in construction.

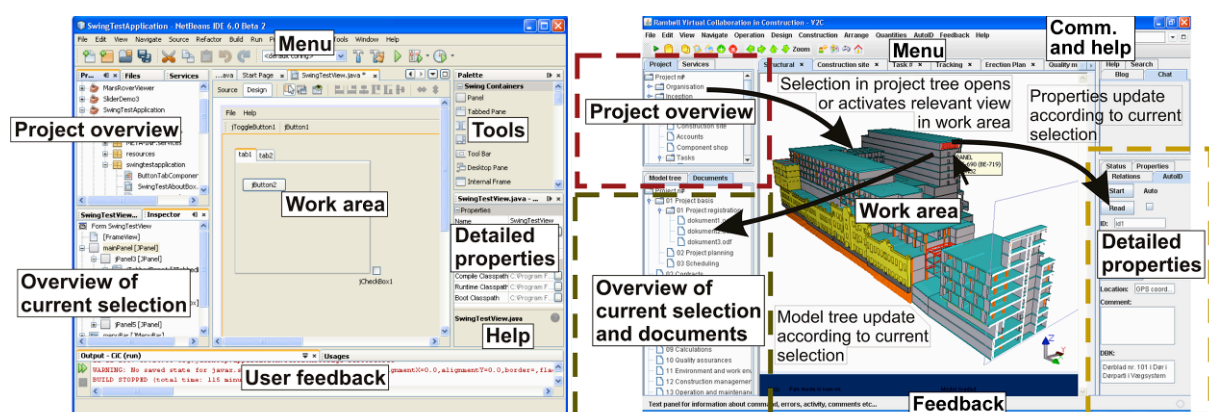

FIG. 13: Left: Screen dump from the integrated development environment (IDE) Netbeans for software development. Right: Prototype of an ICT system for Virtual Collaboration in Construction (V2C).

In figure 14 it is illustrated how V2C is expected to support the linking of virtual models with physical components in construction. Here, it is demonstrated how the actual location of a component selected in the

physical model is shown on a map. In another window, the current production status of the building is illustrated as a 4D model view.

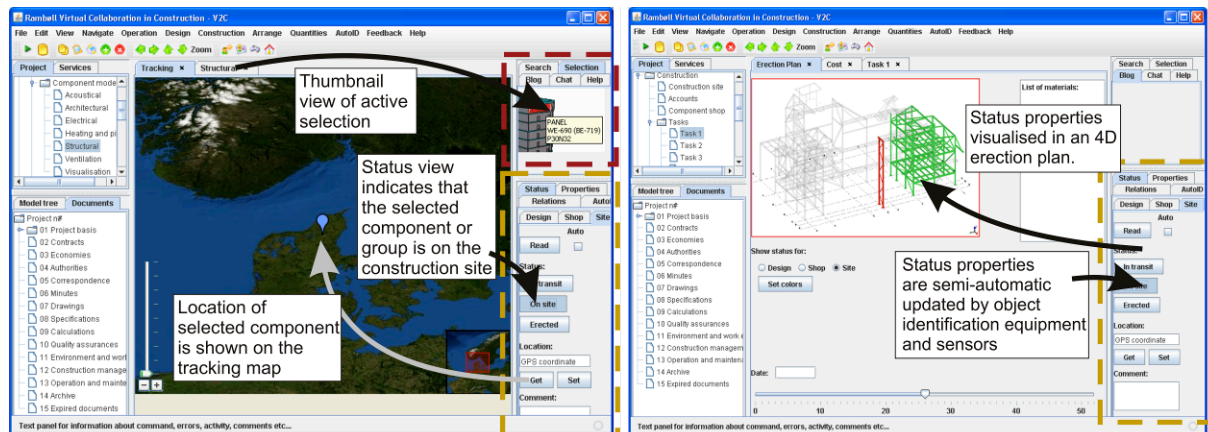

FIG. 14: Screenshots illustrating how the prototype system *Virtual Collaboration in Construction* supports the linking of virtual models with physical components.

## 9.2 User interface for a system for project progress management and quality assurance

Automatic object identification sensors (RFID readers) are needed through the whole supply chain, to keep the virtual model resources updated with information about production status and component locations. The introduction of new ICT tools in construction has however proven to be a challenging task. The one exception that has gained wide acceptance is the mobile phone. Rugged computers, bar code readers or fixed RFID gate readers are often used for logistic optimisation in manufacturing companies, but they have not yet gained ground within construction. Therefore, the focus in the presented prototype developments is to develop new methods and applications that work with the traditional mobile phones rather than using the other tools dedicated for automatic identification. They are today available with embedded RFID reader (Sørensen et al., 2009)

The downside of using a traditional mobile phone as RFID-reader is the fact that the reading range is short (2-3 cm), and the possibilities are limited for developing rich multimedia applications for execution on a small display. Therefore, one of the key challenges is to find a practically usable method both for reading the RFID tags and accessing the virtual 3D and 4D model on mobile devices. Overcoming this challenge with the right system design will also be an important enabler for a wider introduction of the automatic object identification technology and supporting working processes within construction.

In figure 15, screen dumps from a prototype application for project progress management and quality assurance are shown. The idea of the application is to demonstrate what a simple and easy to use mobile application could look like. Another important constraint is that the mobile application should be designed to run on traditional mobile phones with a 240x320 pixels display, which are commonly used today. The prototype is available in an interactive edition for execution on a mobile phone supporting Java 2 Micro Edition, the Connected, Limited Device Configuration and the Mobile Information Device Profile 2.0 (J2ME CLDC/MIDP 2.0) or in mobile phone emulator on a PC. The prototype is exemplified with that Java run-time environment because it is available on today's most popular compact mobile information devices, such as mobile phones and mainstream PDA's. A detailed user environment model was made, prior to the development of the interactive prototype illustrated in figure 15, but it is left out of this paper.

During the prototype development it has been identified that by introducing the object registration in the quality assurance process, no additional work compared to daily working practice is required to keep the virtual models updated with production status information. However, in many organisations it would be necessary to formalise and change today's quality assurance process. It is with this prototype illustrated how the manual paper-based checking and project follow-up now can be done digitally by means of the RFID enabled mobile phones and virtual models.



FIG. 15: Screen dumps from a mobile phone based prototype application for project progress management and quality assurance. From left the screen dumps show 1) some of the menu, 2) input window used by the manufacturer of prefabricated components, 3) output from an inquiry of a component's current location and production status, and 4) output from a full component attributes inquiry.

### 9.3 Test with users

The prototypes were development and tested through an iterative process in cooperation with future users (labourers and construction managers). Knowledge gathered from these tests is included in the affinity diagram in section 5 of the paper. Tests of using RFID technology in practice were conducted in connection with the building project described in section 4.2 of the paper. It included test of: 1) methods for embedding RFID tags in precast concrete elements, 2) readability and reliability of the RFID tags at the construction site, 3) setup requirements of the virtual model to support RFID, and 4) possibilities for use in practice. Some of the functionality of the prototype illustrated in figure 15 was implemented in an operative application on a mobile phone with embedded NFC compatible RFID reader (Sørensen et al., 2009). The mobile phone had on-line GPRS-connection to a data capturing web application. RFID tags were embedded in the precast concrete elements and attached on the outside of the elements. It included most of the wall elements and several of the slabs, beams, and columns for the building project - more than 500 elements in total. The tests showed that the technology works in practice and quick response time can be achieved for the tags attached on the outside of the elements. For the RFID tags embedded in the precast concrete elements satisfactory readability was achieved for approximately 90% of the tags. A combination of the NFC compatible tags with tags with longer reading distances should therefore be considered for embedment in concrete. Another option would be to refine the method for embedding the RFID tags in the concrete. The tests are in the process of being further documented.

## 10. FUTURE EXTENSIONS

Some aspects concerning project progress management, quality assurance and inventory management have not been covered in the prototypes described above. They have though not been forgotten. They have been given lower priority due to this early stage of the development. Only the core functionalities to fulfil the ambitious vision in section 7 of the paper have been included in the prototypes. As earlier mentioned, the vision is to “develop a simple and implementable system and supporting work processes for real time project progress management, quality assurance and inventory management.” In this section of the paper the relevant future extensions of the system will shortly be outlined and discussed. They are important to be aware of in the implementation of the described prototypes to avoid putting restraints on systems, which in the near future will cause conflicts with the user needs.

**Automation of the data collection:** This prototype system is solely based on data capture from mobile phones because they are cheap, highly flexible, easy to carry, and already implemented in construction. One of the drawbacks of using the mobile phone for data capture is that it requires manual attention. Automatic readers on trucks, gates, etc., can avoid some of the manual work required for the data capture. However, it should be noticed that no extra work will be introduced by the described system. At all the stages where the system is going to be used for data capture, a manual and often paper-based quality assurance procedure is conducted today (shipping from manufacturer, acceptance control at the building site and documentation when installed), so the additional benefits from using fully automatic identification are expected to be rather limited.

**Integration with other systems:** The idea behind the use of a separate virtual model service (as illustrated in the figures in section 7 of the paper) for the data capture is to create a flexible solution that is easy to integrate into other systems, such as business enterprise resource planning systems (ERP), various CAD systems, room and equipment databases, production planning tools and operation and maintenance systems.

**Integration through standardised data representations:** The Industry Foundation Classes (IFC) data model, developed by IAI, is most likely the most important data representation form of virtual model data for the construction industry in the future. For that reason future extensions of the system should contain integration with IFC model servers through standardised data exchange. This will support improved inter-organisational use of the systems and a better scalability.

**Visualisation, reporting and optimisation of the construction process based on the captured data:** The prototype presented has some focus on visualisation and optimization, but many other possibilities will turn up when the system is a reality. There will for example be many possibilities for different kind of reports, such as lists of deviations between planned and realised construction.

**Use of RFID tags with long reading distances and active tags with sensors:** When designing new RFID based systems, it is very important to focus on the core business issues. In this case the core business problem is to develop a system that supports working methods enabling user-friendly information delivery and real time data capture of the project progress and quality assurance documentation. Therefore, the use of more advanced RFID tags and readers will not create significantly more value. The fully flexible mobile solution is much more important. When e.g. UHF EPC (Electronic Product Code, (EPCglobal, 2008)) readers are available for standard mobile phones, like the NFC (Near Field Communication) technology is today and current challenges concerning the use of UHF tags together with metals are solved, it should be considered to use these tags. It is also expected that dual or tri band (LF+HF+UHF) RFID tags would be useful for the construction industry because no single RFID technology meets all the requirements to RFID tags for use in the construction industry.

**Legal aspects must be covered:** A number of legal questions should be clarified such as: Who is the virtual model data owner, who is responsible for updating what kind of information in the virtual model and what can the data be used for?

**Detailed check lists in the quality assurance:** It should be considered to include more detailed check lists in the quality assurance (QA) process. It is, however, currently not done because it has been identified that the four options: 1) Approve, 2) Reject, 3) Approve with comments, and 4) Fixed, supplemented by the ability to add comments will cover most user needs. It also makes the system very flexible and it only requires the user to enter deviations, and it does not overtax him/her with unnecessary registration work.

**Product data life cycle management:** Comprehensive use of virtual models as illustrated with the prototypes in this paper introduces a need to consider and develop methods for accessing and re-using the data in the full life-time of the building.

**Optimisation for other platforms:** The presented prototypes have been developed for use on regular PC's and mobile phones. New display technologies and the introduction of ultra mobile low cost and rugged laptops such as the One Laptop per Child (OLPC) (OLPC, 2008) are expected to have a positive influence on the use of ICT at construction sites. Therefore future implementations should be able to take advantage of these technologies. In figure 16 it is illustrated how a construction detail and a web site containing work instructions (in this case a Wiki) easily can be viewed on the OLPC even on a rainy day or a very sunny day. OLPC is water resistant and in contrast to most displays on common mobile phones and laptops it can be used in direct sunlight due to a reflective display. These features are important to be aware of when developing a future system supporting One Laptop per Workman (OLPW).

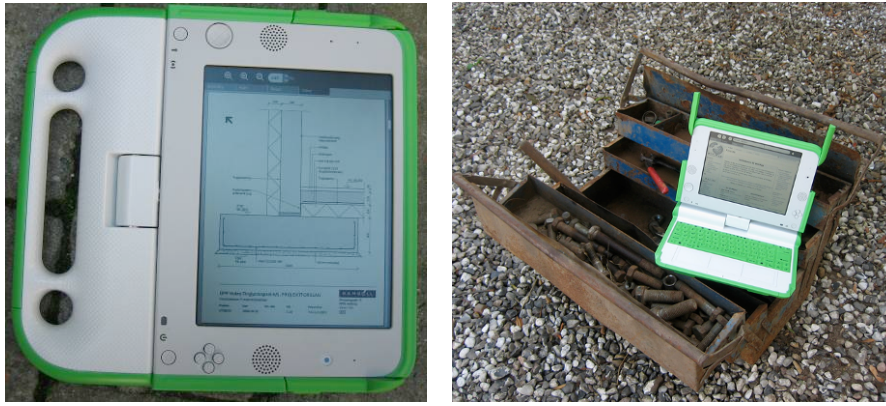

FIG. 16: Illustration of how the OLPC can be used for displaying construction details and work instructions.

## 11. CONCLUSIONS

The initial idea behind the research presented in this paper was to identify and formalise user needs in relation to construction management by means of virtual models and RFID. The Contextual Design method was found useful in the research process, when developing ICT system prototypes (an early example) and as a framework for capturing the user needs.

Based on three case studies and involvement of more than 20 future users, an extensive list of future user needs was discovered. They are in the paper presented in an affinity diagram of challenges to be addressed, and as potential that can be utilised e.g. by new ICT systems. It was found useful to structure the affinity diagram of the captured observations according to their relevance to the overall strategy, organisation and working processes, technology and infrastructure, human resources, physical components, virtual models in construction management, quality assurance, and social and political aspects. For a successful future system development and implementation, a number of challenges to be addressed were identified such as 1) need to integrate interorganizational and conflicting working processes, 2) lack of interoperability and de facto standards, 3) need for better integration of the traditional paper document/drawing based working practice into modern virtual model based working paradigms, and 4) need for new competences at the middle management level or a project information officer (PIO) service function who would be responsible for implementing the technology at the construction site.

However, great potential has also been identified, e.g. 1) mobile phones can be an important key to introduce a wider introduction and use of RFID in construction, 2) a combination of automatic identification technology and lean construction principles can give new possibilities for process optimisation, 3) use of automatic identification can introduce a new object-oriented paradigm for quality assurance in construction, and 4) the combination of RFID and GPS technology can enable real-time tracking and location of machines and materials.

A prototype was developed of a simple and implementable system with supporting working processes for real-time project progress management, quality assurance and inventory management in order to provide further insight in how the potential and challenges can be addressed. By this prototype it is illustrated how today's manual and paper-based checking and project follow-up can be done digitally by means of the RFID enabled mobile phones and virtual models.

A prototype of a new collaboration tool for Virtual Collaboration in Construction (V2C) is also presented. It illustrates a possible user-interface to a collaboration tool that can support the link between virtual models and physical components in construction.

The prototypes presented in this paper are preliminary conceptual work that has to be implemented, and further it has to be validated by full-scale tests. The authors expect the prototypes can act as a basis for future developments of interfaces to e.g. model server managers, and development of mobile data capturing equipment. The research and development was done as a highly iterative and user involving process, and was based on a well-documented methodology (Contextual Design), which despite of lack of full scale tests, improves the validity of the findings.

## 12. ACKNOWLEDGEMENTS

The research underlying this paper is financially supported by Ramboll Denmark A/S and the Danish Ministry of Science, Technology and Innovation.



### 13. REFERENCES

- Aalborg Engineering (2008). Aalborg Engineering web site, available at <http://www.aalborg-engineering.com/>
- Alvesson, M. and Sköldböck, K. (2000). *Reflexive Methodology – New Vistas for Qualitative Research*, SAGE Publications Ltd, 2000, 319 pp.
- Apelgren, S., Richter, A. and Koch, C. (2005). *Snublesten i byggeriet, R-107, BYG·DTU*, 175 pp.
- bips (2007): *3D Working Method 2006*. National Agency for Enterprise and Construction, (bips is a Danish organisation and the acronym denote Construction, IT, Productivity and Cooperation), 76 pp.
- Beyer, H. and Holtzblatt, K. (2000). *Contextual Design*, Morgan Kaufmann Publishers, 472 pp.
- Chesbrough, H. (2006). *Open Business Models: How to Thrive in the New Innovation Landscape*. Harvard Business School Press, 256 pp.
- Chin, S., Yoon, S., Kim, Y-S, Ryu, J., Choi, C., Cho, C-Y. (2005). *Realtime 4D CAD + RFID for project progress management*, ASCE Construction Research Congress 2005, 10 pp.
- Christiansson, P. (1984). *Integrated Computer Aided Design. Present and Future Data Structures*. CIB, WC78, Colloquium London, June 5-7 1984, Publication 78, pp. 20-25. (Available at <http://it.civil.aau.dk/it/publications>)
- Christiansson, P., Da Dalto, L., Skjaerbaek J. O., Soubra S., Marache, M. (2002). *Virtual Environments for the AEC sector - The Divercity experience*, ECPPM 2002, Proceedings of the European Conference of Product and Process Modelling. eWork and eBusiness in AEC. Swets & Zeitlinger Publishers, Lisse The Netherlands, Portoroz, Slovenia, pp. 49-55.
- Christiansson P. (2007). *ICT Enhanced Buildings Potentials*, Proceedings 24th CIB W78 Conference "Bringing ICT knowledge to work", Maribor, Slovenia, pp. 373-378.
- Eastman, C., Teicholz, P., Sacks, R., Liston, K. (2008). *BIM Handbook: A guide to Building Information Modeling for Owners, Managers, Designers, Engineers, and Contractors*. John Wiley & Sons, Inc., 504 pp.
- EPCglobal, (2008). *EPCglobal Standards Overview*, web-site. (available at <http://www.epcglobalinc.org/standards/>)
- Froese, T. and Han, Z-H. (2008). *Developing the Discipline of Project Information Management*, Proceedings of the 12th International Conference on Computing in Civil and Building Engineering & 2008 International Conference of IT in Construction (ICCCBE XII & INCITE 2008), 6 pp.
- Göransson, B., Lif, M., Gulliksen, J. (2003). *Usability Design—Extending Rational Unified Process with a New Discipline*, Dept. for IT/HCI, Uppsala University, Sweden, 15 pp.
- Jacobson, I., Booch, G., Rumbaugh, J. (2005). *The Unified Software Development Process*, Addison-Wesley, 512 pp.
- Java (2008). *The Java Tutorials*, web-site, available at <http://java.sun.com/docs/books/tutorial/>
- Josephson, P.-E. and Hammarlund, Y. (1999). *The causes and costs of defects in construction*, *Automation in Construction* 8, pp. 681–687.
- Karhu, V., Keitilä, M., Lahdenperä, P. (1997). *Construction process model - Generic present-state systematisation by IDEF0*. VTT Building Technology, Technical Research Center of Finland, 190 pp.
- Liebich, T., Adachi, Y., Forester, J., Hyvarinen, J., Karstila, K., Richter, S., Wix, J. (2008). *IFC2x Edition 4 alpha version*, web-site, buildingSMART. (available at <http://www.iai-tech.org/>)
- Mourgues, C. (2008). *Method to Produce Field Instructions from Product and Process Models*. Ph.D. Diss., Stanford University, 197 pp.
- MT Hojgaard (2008). *MT Højgaard web-site*, available at <http://www.mthojgaard.dk/>
- NAEC (2005). *Digital Construction*. National Agency for Enterprise and Construction, 8 pp.
- NAEC (2006). *BEK nr. 1365 af 11/12/2006, Bekendtgørelse om krav til anvendelse af Informations- og Kommunikationsteknologi i byggeri*, LOV Nr. 228 af 19/05/1971, National Agency for Enterprise and Construction, 2 pp.

- Nielsen, J. and Loranger, H. (2006). *Prioritizing Web Usability*, New Riders Press, 432 pp.
- OLPC (2008). OLPC web site, available at <http://laptop.org>
- Ramboll (2008). Ramboll web site, available at <http://www.ramboll.com>
- Sacks, R., and Barak, R. (2008). Impact of three-dimensional parametric modelling of buildings on productivity in structural engineering practice, *Automation in Construction* 17, pp. 439–449.
- Steinmann, R. (2005): The Job Profile of Construction Informatics, *Proceedings of CIB, W78 Conference*, 4 pp.
- Sørensen, K.B., Christiansson, P., Svidt, K., Jacobsen, K., Simoni, T. (2009). Ontologies to Support RFID Based Link between Virtual Models and Construction Components, *Computer-Aided Civil and Infrastructure Engineering* (submitted October 2008).
- Sørensen, K.B., Christiansson, P., Svidt, K., Jacobsen, K., Simoni, T. (2008). Radio Frequency Identification in Construction Operation and Maintenance – Contextual Analysis of User Needs, *Proceedings of the 12th International Conference on Computing in Civil and Building Engineering & 2008 International Conference of IT in Construction (ICCCBE XII & INCITE 2008)*, 6 pp.
- Pyzdek, T. (2003). *The Six Sigma Handbook: A Complete Guide for Green Belts, Black Belts and Managers at All Levels*. McGraw-Hill Professional, New York., 848 pp.
- Wamba, S.F., Lefebvre, L.A., Bendavid, Y., Lefebvre, E. (2007). Exploring the impact of RFID technology and the EPC network on mobile B2B eCommerce: A case study in the retail industry. *International Journal of Production Economics* 112, pp. 614–629.
- Woksepp, S. (2007). *Virtual reality in construction – tools, methods and processes*. Ph.D. Diss., Luleå University of Technology, 188 pp.

*This paper is available electronically at <http://itcon.org>*